

THIS DOCUMENT CONTAINS PROPRIETARY DATA OF POLARIS INDUSTRIAL ENTERPRISES, INC. NO DISCLOSURE, REPRODUCTION, OR USE OF ANY PART THERE OF MAY BE MADE EXCEPT BY WRITTEN PERMISSION.

REV.	BY	DATE	APPRVL.	P/N
				VK21-XXXX

ASSEMBLY

VALVE SHOULD BE MOUNTED TO THE BRACKET AS SHOWN. TURN VALVE STEM TO VALVE SHUTOFF BY HAND. LOOSEN THE SET SCREWS ON THE ADAPTER. SLIP ADAPTER AND COUPLER OVER VALVE STEM. MAKE SURE THE COUPLER AND ADAPTER ROTATES FREELY, SLIP ACTUATOR SHAFT INTO COUPLER SQUARE OPENING. SECURE BRACKET TO ACTUATOR USING 6 10-32 CAP SCREWS. TURN ON ACTUATOR AND SUPPLY 20 MA SIGNAL WAIT UNTILL IT STOPS ROTATING. SUPPLY 4 MA SIGNAL ACTUATOR WILL ROTATE TO CLOSE POSITION AND STOP. ACTUATOR AND VALVE ARE BOTH IN CLOSED POSITION. TIGHTEN THE SET SCREW ON THE VALVE STEM.

BRACKET
ALUMINIUM ANODIZED

COUPLER
BRASS, NICKEL PLATED
SET SCREWS, PINS
ARE STAINLESS STEEL

MOUNTING HOLES FOR
10-32 CAP SCREWS

TYPE OF VALVES

NEEDLE VALES
METERING VALES
BALL VALVES
BELOWS VALVES

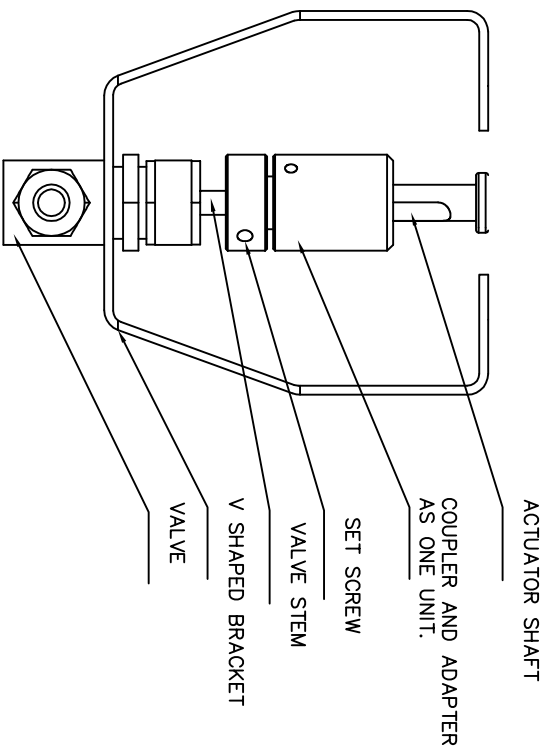
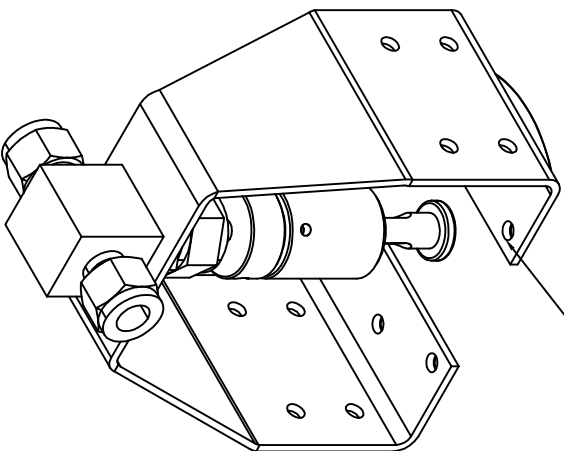

SCALE	DATE:	3-31-23
NONE	BY	AT
CODE	APPRV'D	
IDENT:	19477	

ETI SYSTEMS
1954 KELLOGG AVE.
CARLSBAD, CA 92008
(760)-929-0749
ETISYSTEMS.COM

TITLE
MOUNTING
ILLUSTRATION

PART NO.
VK21-XXXX